



Oceanlift Cranes and Davits



Oceanlift New Zealand

P.O. Box 303 012 North Harbour 0751 North Shore City New Zealand
Ph+649 4447537 Fax+649 4447511
mark@oceanlift.co.nz www.oceanlift.co.nz www.besenzoni.co.nz

Oceanlift Cranes & Davits



Oceanlift is New Zealand's largest, most experienced and enduring crane manufacturer. We have been designing and manufacturing cranes and davits to suit recreational and commercial boats since 1997.

We create our own new ideas - we do not copy other manufacturers.

We have made it our mission to create innovative alternatives to the common faults and shortcomings suffered by other brands.

The Oceanlift Difference

- *No ferrous winch parts. We remove or seal in all steel parts to prevent rusting.
- *We don't cut corners with poor quality components such as cheap winches.
- *We heat-bond a polymer cover over the winch motor to seal in and waterproof the motor and electrical connections so it does not require four yearly replacement and bleed rust on your deck.
- *We build in a significant overload allowance so in the event of accidental overload, disaster is avoided.
- *Superior coating—we apply an etched undercoat to prevent corrosion and a heat cured gloss protective coat that retains its good looks for years.
- *We individually design and tailor every crane to perfectly suit its purpose and to fit the boat/tender combination,
- *We are proud to be the choice of harbour boards, commercial and charter operators, police and recreational users.
- *There are no grease points or metal to metal contact in Oceanlift cranes.
- *Our cranes are made to perform and to look their best for decades.



We make Oceanlift cranes in a range of standard configurations and custom dimensions to suit your application.



The Oceanlift advantage.

We believe in offering cranes that are sufficiently strong to cope with unexpected shocks, properly tailored to fit your boat and free from corrosion, free from premature cable failures and difficulties in operation.

We can create a properly tailored crane - standard or custom, for you.



One size does not fit all situations so we believe that every Oceanlift crane owner should have a crane properly fitted to easily transfer the tender to the water and back into the cradle, without touching the boat or rail. We visit the boat or tailor fit from plans (depending upon location) to work out the best design and dimensions for your crane.

Our unique components and systems allow a wide range of customisation and innovation at little or no extra cost.

Oceanlift™ LD electric winch crane 200kg, 400kg options.

Dimensions flexible made to order
Boom reach between 1.5M—2.5M
Height off deck 500mm up to 750mm (stowed height)
Standpipe up to 2.0M
Winch left, right or under boom
Colour optional - White standard

Boom incline 25 or 30 degrees

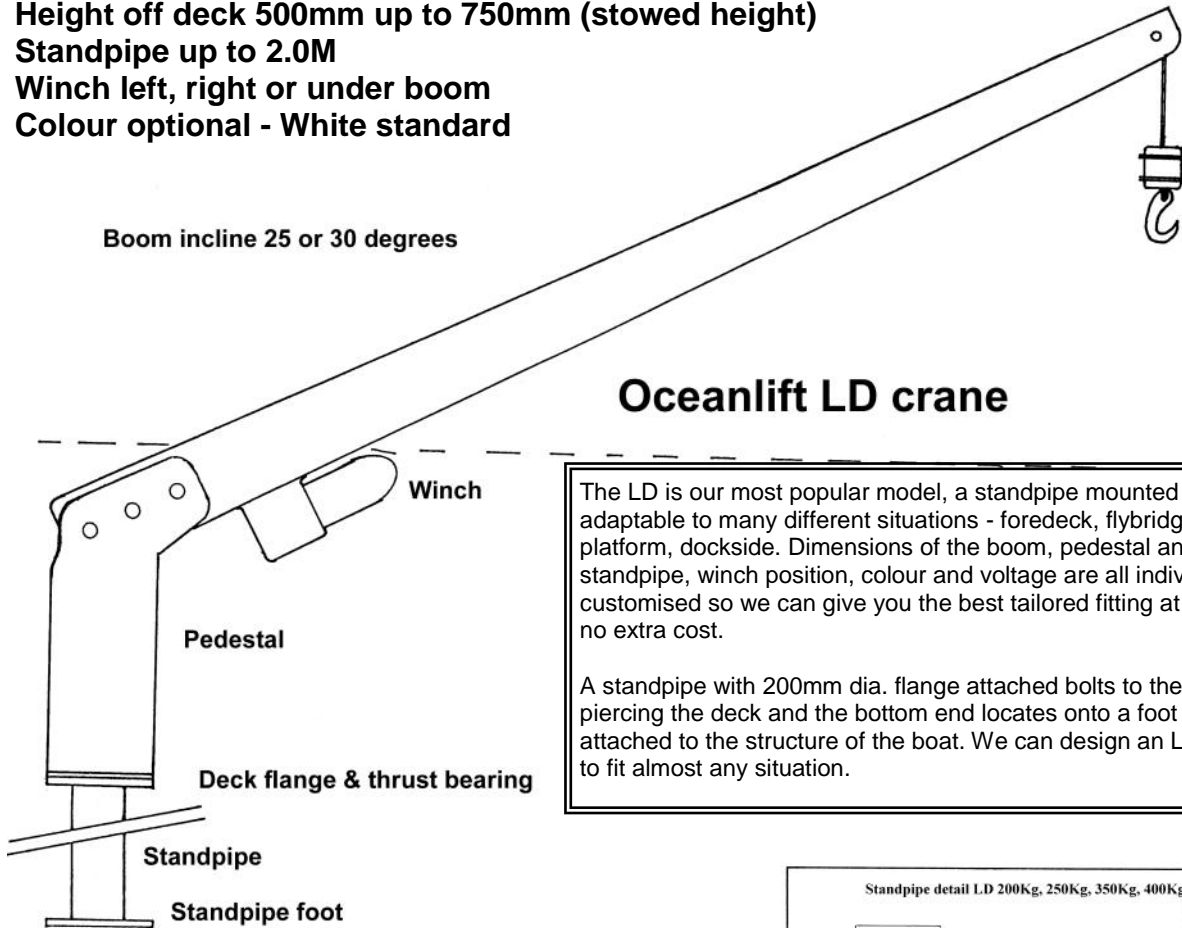

Oceanlift LD crane

The LD is our most popular model, a standpipe mounted crane adaptable to many different situations - foredeck, flybridge, platform, dockside. Dimensions of the boom, pedestal and standpipe, winch position, colour and voltage are all individually customised so we can give you the best tailored fitting at little or no extra cost.

A standpipe with 200mm dia. flange attached bolts to the deck piercing the deck and the bottom end locates onto a foot casting attached to the structure of the boat. We can design an LD crane to fit almost any situation.

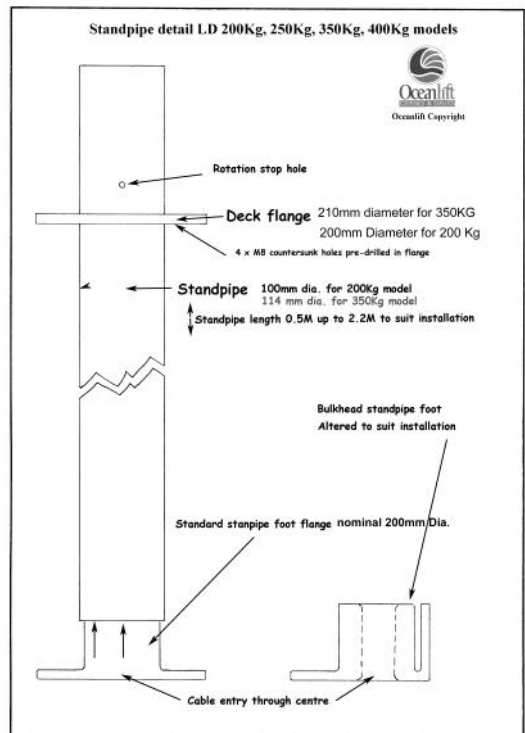

Oceanlift™ LDF electric winch crane flange base 200kg, 400kg options.

- Dimensions Optional
- Boom reach between 1.5M—2.5M
- Height off deck 500mm up to 750mm
- Winch left, right or under boom
- Flange base 460mm x 460mm

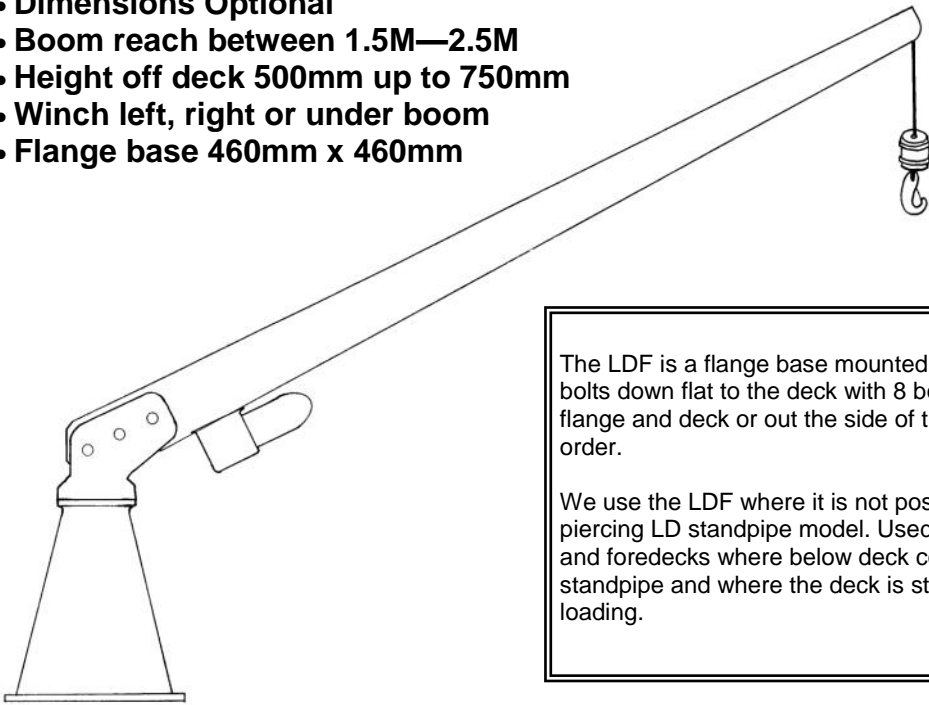

The LDF is a flange base mounted crane - a 460mm square flat flange bolts down flat to the deck with 8 bolts, cables can exit through the flange and deck or out the side of the box. Other flange sizes made to order.

We use the LDF where it is not possible or desirable to use a deck piercing LD standpipe model. Used on overhanging flybridge decks and foredecks where below deck configuration prevents the use of a standpipe and where the deck is strong enough to support the surface loading.



Oceanlift™ HD100 Hand operated Davit 100kg maximum safe working load.

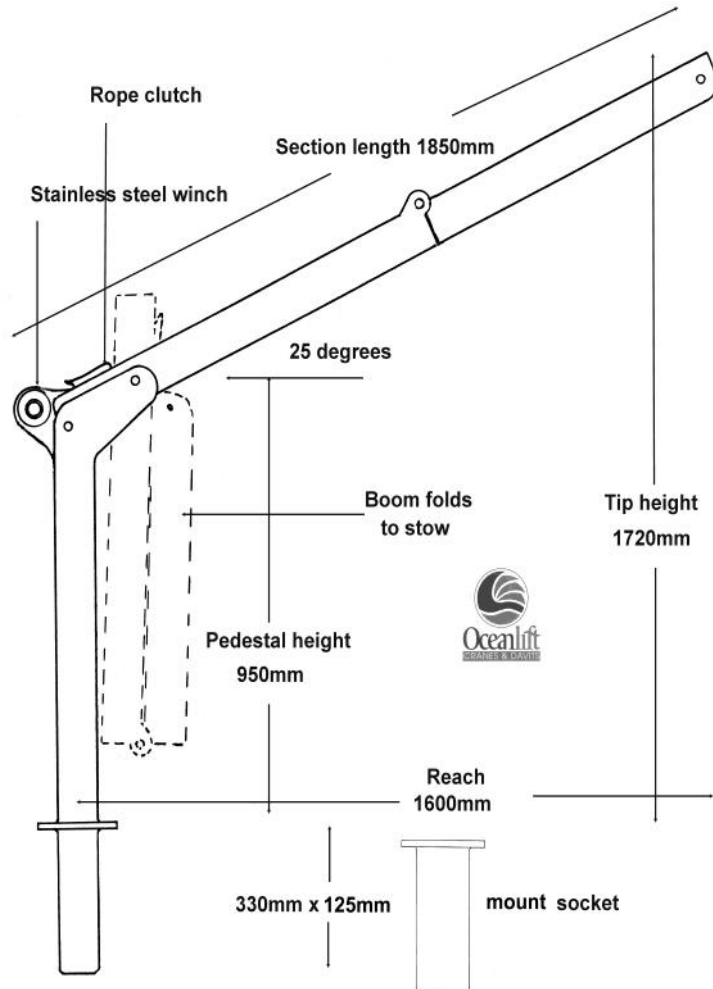

- Our smallest - hand operated up to 100Kg safe working load, perfect for small tenders.
- Simple mounting—125mm dia. socket mounting base extends only 330mm below deck, 200mm dia. flange bolts to the deck & against bulkhead.
- Hand operated lift and lower — Andersen #10 stainless steel standard winch with Rutgerson rope clutch to control the loaded rope and prevent accidental release.
- Maximum 100Kg safe working load.
- Durable and attractive white gloss finish, structure made from high tensile marine aluminium.
- Very easy to rotate boom 360° with dinghy suspended—due to the nylon bearings - no grease or metal to metal contact.
- Simply fold up and capture with bungy ready to stow.
- Easily removable to stow in another location—only weighs 20kg. The HD100 can be supplied with multiple deck sockets so the crane can be used in more than one position.



Oceanlift™ Custom cranes.

We conceive, design and manufacture cranes to fit commercial and recreational applications. Our modular systems are adaptable to suit a wide range of configurations for use on land and water.



A few of the many design options we can use to make a crane to suit almost any requirement:

- Fixed standpipe or rotating standpipe mounted, for boat, wharf pole or concrete pad
- Flange base mounted in stainless steel or aluminium for dock or jetty.

<ul style="list-style-type: none"> Fixed boom or folding boom Up to 500Kg SWL lift capacity Boom length up to 3.5M for some models Rotation stops Folding pedestal Cranes for Docks, Jetties, Wharves, Decks, Houses and Boats 	<ul style="list-style-type: none"> Folding pedestal Winch type and position Gas spring assistance Disabled person lift
--	--





Oceanlift™ LD 500 kg SWL electric winch crane 3.0M -3.5M boom length.

This model is currently under development and will be ready during 2011.

We have incorporated some revolutionary features in this new model that will enable it to be fitted into many different situations within the standard configuration.

- Variable boom luff angle - any point between horizontal and 45° - to change the boom reach which is much easier than a manually telescoping boom. Pre-set angle before lifting by winding the hand operated mechanism until the desired angle is reached.
- 12 or 24VDC cable winch, hand operated slew 350° and hand wound boom luff, from horizontal up to 45°.
- Completely concealed winch - no ugly bumps or humps.
- Low level when stowed, 680mm above the deck.
- High tensile marine aluminium construction with stainless steel standpipe, one piece and self waterproofing.
- Durable baked on, gloss finish over a chemically bonded primer.
- Minimal maintenance, self lubricating bearings - no grease or metal to metal contact.

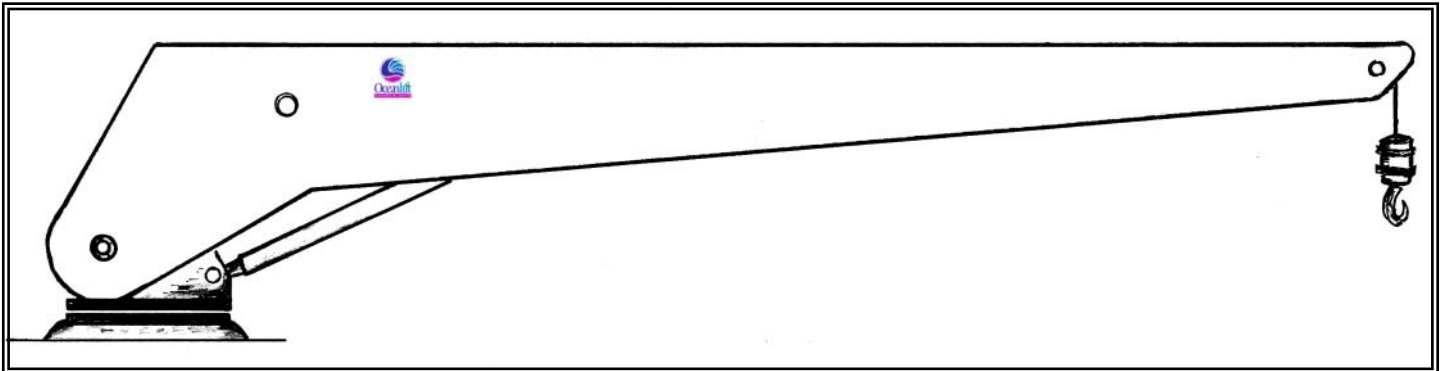

- Options
- Boom lengths between 2.5M and 3.5M
 - Short-lift connections
 - Twin winches
 - Deck flange height - flat or raised
 - Colour (white is standard).

Oceanlift Cranes & Davits



We semi-custom create all Oceanlift models (except HD100) – boom length, pedestal height, standpipe length and other features.

- Finished in durable gloss white Duratec® over a special etched primer to prevent corrosion and look good for decades
- Marine grade high tensile aluminium construction with stainless steel fittings
- Boom, pedestal and standpipe electrically isolated to prevent corrosion and shock
- All bearings are self lubricating eliminating the need for grease or metal to metal contact
- Electric Cranes fitted with the durable and quiet GP series (made in the USA) Superwinch—12 or 24 volt options— with hand held remote
- The winch has been Oceanlift® modified to preserve it and prevent corrosion and water ingress
- Hand winch models fitted with Andersen stainless steel winches with Rutgerson rope clutch—a hand winch option is available on all electric cranes
- Spectra or Dyneema winch line fitted with counter weight & hook on all electric cranes
- Designed & manufactured in New Zealand.

How to order an Oceanlift crane

Oceanlift cranes are made to custom dimensions. We do this to ensure that the crane is able to lift the dinghy clear of the deck, over the rail and into the water with clearance over the rail and the side of the boat.

If your boat is located in Auckland, Northland, BOP or Taupo we will visit (at no extra cost) to work out the best crane dimensions and model for you. For any other locations, we can take details from our questionnaire or a boat plan.

We produce a drawing of the proposed crane to work out the best dimensions and design for you so that you know how your Oceanlift crane will look, stow and function.

Installation: We suggest that a boat builder installs the crane to your boat or an appropriate professional fits it to your dock or seawall. We are happy to advise your installer.

• Our models

- LD standpipe mounted
- 200, 400Kg SWL
- LDF Flange base mounted. 200, 400Kg SWL
- 2F standpipe mounted 2 piece fold down 200, 400Kg SWL
- 3F standpipe mounted 3 piece fold down 200, 400Kg SWL
- LDPF Standpipe mount folding boom stowed inside portofino or bulwark 200 or 400Kg SWL
- Seawall Extra tall flange mount for docks or seawall, 200 or 400Kg SWL
- HD100 folding boom, socket mount, hand winch 100Kg SWL
- LD500 new model 500Kg SWL with 3.5M boom length and infinitely variable boom luff angle.





Dimensions & Details required.

See picture attached.

Boat

- A.Height between rail foot to point on deck marking proposed centre of crane standpipe. Must be level.
- B.Rail height.
- C.Outside of belting/rail to proposed centre of crane standpipe.
- D.Centre of standpipe to centre of gravity of tender(Horizontal Reach).
- E.Sheer height difference of rail between centre of standpipe & reach distance fwd where dingy passes over rail.

Tender

Type: Rigid Inflatable PWC/jetski Rigid dinghy (Circle one)

- F.Tender beam overall.
- G.Tender overall height top of tubes or gunwale to keel at transom
- H.Tube diameter (If RIB).
- I.Tender overall length.
- J.Chine to chine beam (If rigid dinghy)

Other

-Voltage?
-Which side of boat is crane mounted on?
-Winch motor facing inboard or outboard when crane stowed?
-Deck material (steel, wood, fibreglass laminate etc)
-Boat design & size.

This Drawing and design are the sole property of Technical Equipment Marine & Oceanlift. ©Copyright Oceanlift®

